

These drawings and designs are copyrighted, and must not be copied or reproduced.

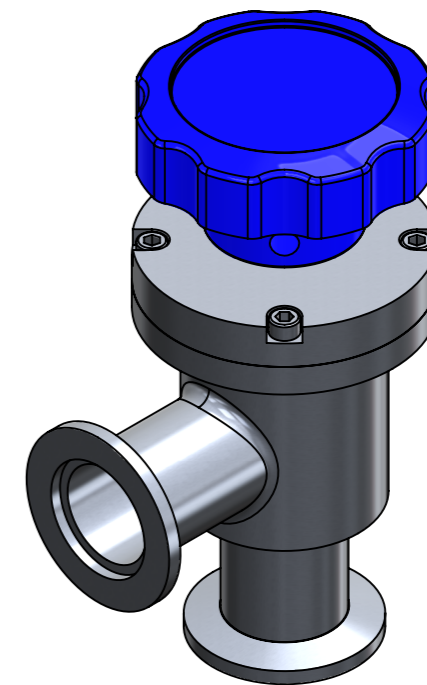
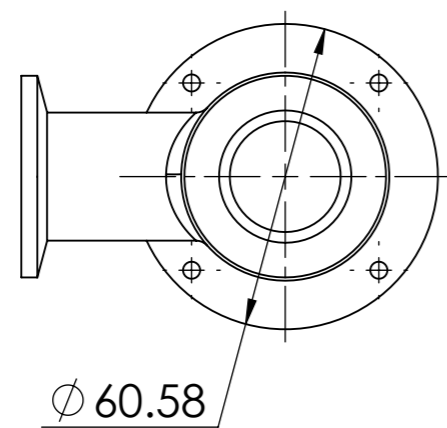
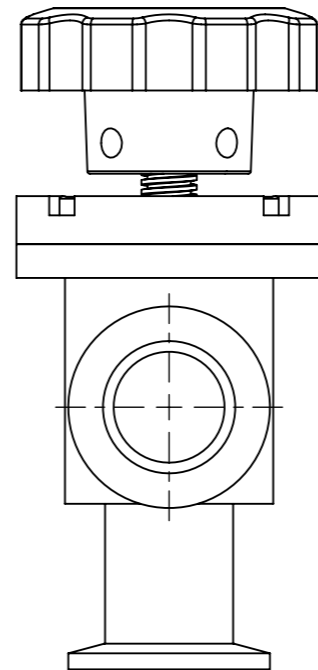
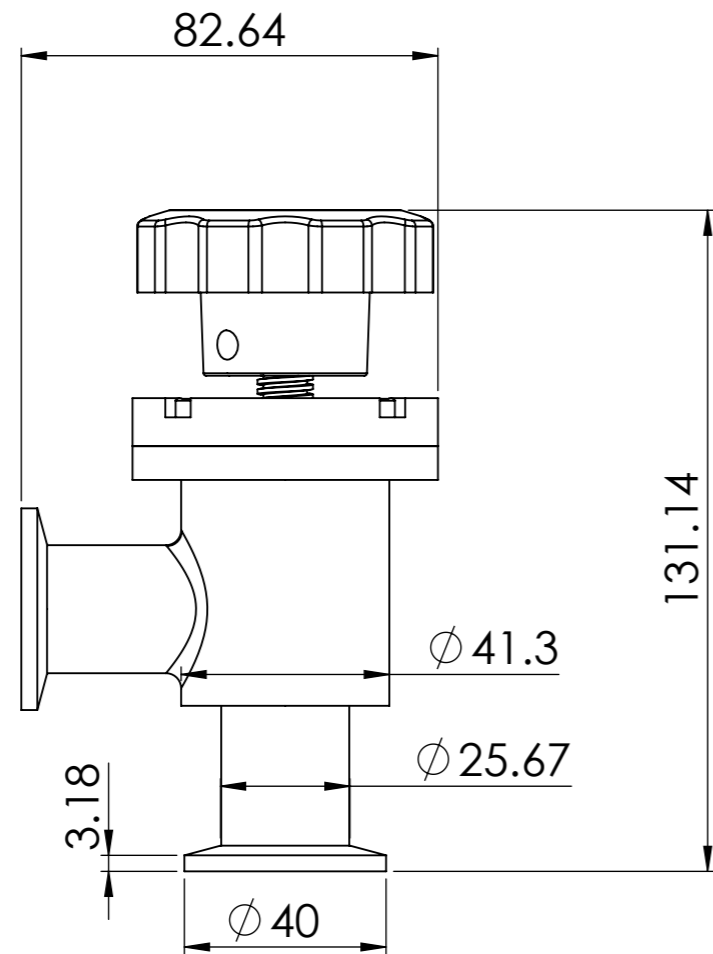

Tolerance for machined surfaces unless otherwise specified		mm	Name	Date	Sign	Sheet	WAVE FREEZEDRYER		
0 DECIMAL PLACES : +/- 0.50mm	ANGLES TOLERANCES					1/1			
1 DECIMAL PLACES : +/- 0.25mm	0 DECIMAL PLACES : +/- 1.00°	Draw	Thach Ng.	3/21/2024					
2 DECIMAL PLACES : +/- 0.10mm	1 DECIMAL PLACES : +/- .50°	Control							
3 DECIMAL PLACES : +/- 0.02mm	SURFACE FINISH 125 Ra MAX								
CONCENTRICITY .25mm TIR	BREAK ALL EDGES TO .35mm x 45°								
REMOVE ALL BURRS									
INSIDE CORNERS 0.4mm - 0.8mm R	CHECK HARDNESS AT STAMPED PRODUCT NUMBER LOCATION								
ALL DIMENSIONS ARE IN MILLIMETERS									
<small>THIS DRAWING IS THE INTELLECTUAL PROPERTY OF WAVE FREEZEDRYER AND MAY NOT BE REPRODUCED IN WHOLE OR IN PART WITHOUT THE WRITTEN PERMISSION OF THE OWNER. ANY RECIPIENT AGREES BY ACCEPTING AND POSSESSING IT, NOT TO DISCLOSE ANY INFORMATION CONTAINED HEREIN TO ANY PERSON OR ENTITY EXCEPT WITH THE AUTHORITY OF WAVE FREEZEDRYER, OR USE IT FOR ANY OTHER PURPOSE OTHER THAN FOR WHICH IT IS INTENDED.</small>							Part Number Manual Valve KF25	Size: A4	Material Material Spec Surface Coating
		Scale	1:1.5						