

These drawings and designs are copyrighted, and must not be copied or reproduced.

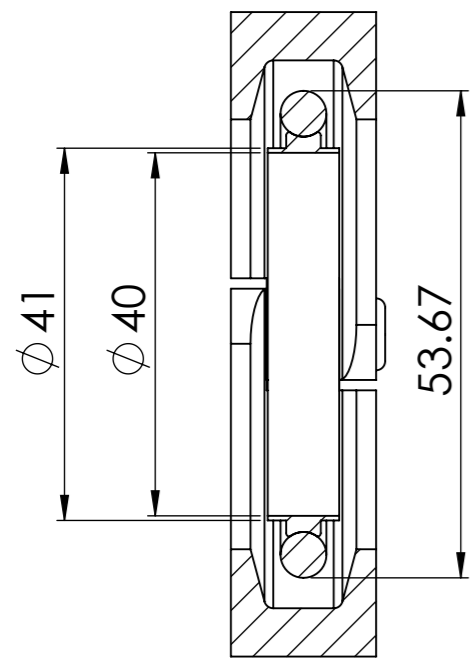

SECTION E-E

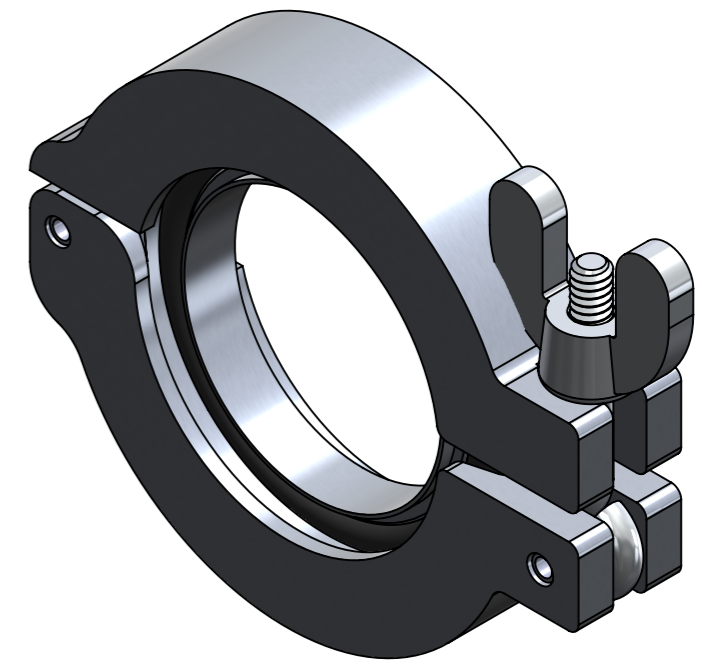
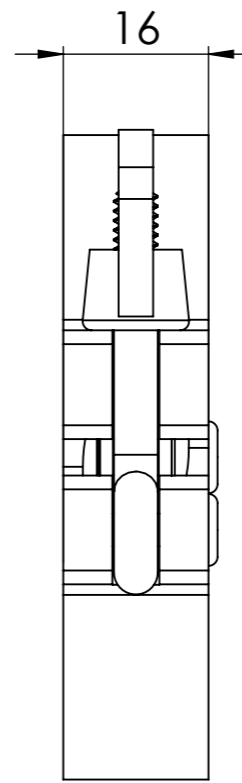
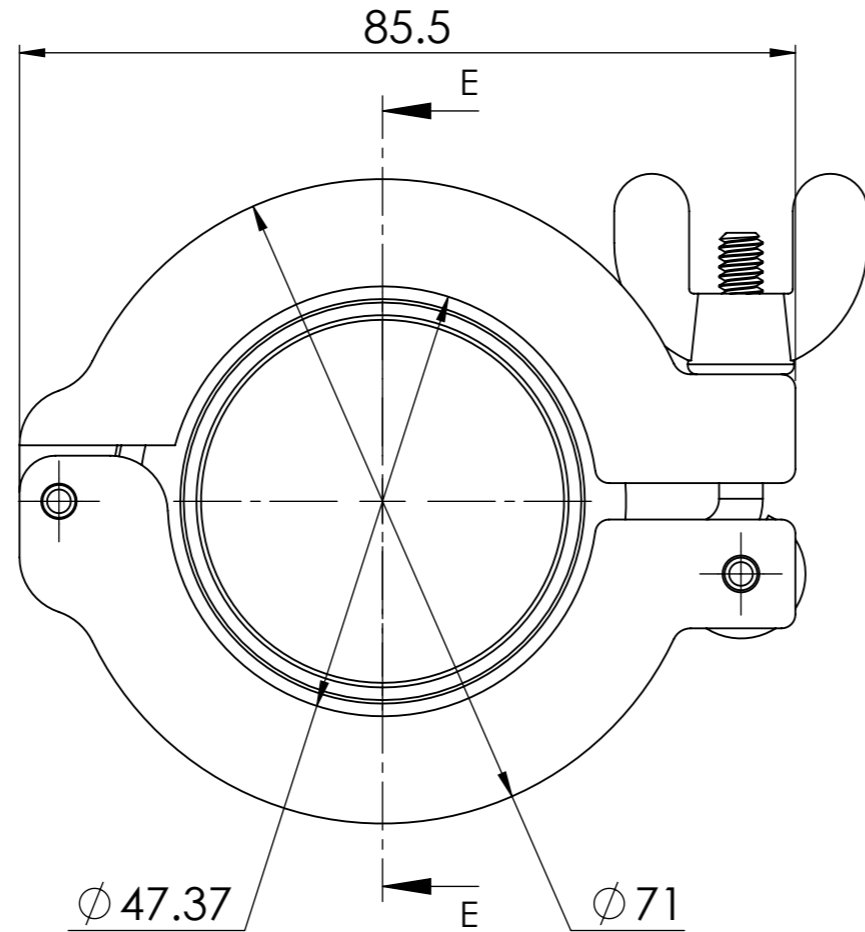

Tolerance for machined surfaces unless otherwise specified	
LINEAR TOLERANCES 0 DECIMAL PLACES : +/- 0.50mm 1 DECIMAL PLACES : +/- 0.25mm 2 DECIMAL PLACES : +/- 0.10mm 3 DECIMAL PLACES : +/- 0.02mm CONCENTRICITY : 25mm TIR INSIDE CORNERS 0.4mm - 0.8mm R ALL DIMENSIONS ARE IN MILLIMETERS	ANGLES TOLERANCES 0 DECIMAL PLACES : +/- 1.00° 1 DECIMAL PLACES : +/- .50° SURFACE FINISH 125 Ra, MAX BREAK ALL EDGES TO .35mm x 45° REMOVE ALL BURRS CHECK HARDNESS AT STAMPED PRODUCT NUMBER LOCATION
<small>THIS DRAWING IS THE INTELLECTUAL PROPERTY OF WAVE FREEZEDRYER AND MAY NOT BE REPRODUCED IN WHOLE OR IN PART WITHOUT THE WRITTEN PERMISSION OF THE OWNER. ANY RECIPIENT AGREES BY ACCEPTING AND POSSESSING IT, NOT TO DISCLOSE ANY INFORMATION CONTAINED HEREIN TO ANY PERSON OR ENTITY EXCEPT WITH THE AUTHORITY OF WAVE FREEZEDRYER, OR USE IT FOR ANY OTHER PURPOSE OTHER THAN FOR WHICH IT IS INTENDED.</small>	

mm	Name	Date	Sign	Sheet	WAVE FREEZEDRYER	
Draw	Thach Ng.	3/21/2024		1/1	Material	
Control					Material Spec	
Scale 1:2	Part Number			Size:	Surface Coating	
	KF40 Ring and Clamp			A4		