

These drawings and designs are copyrighted, and must not be copied or reproduced.

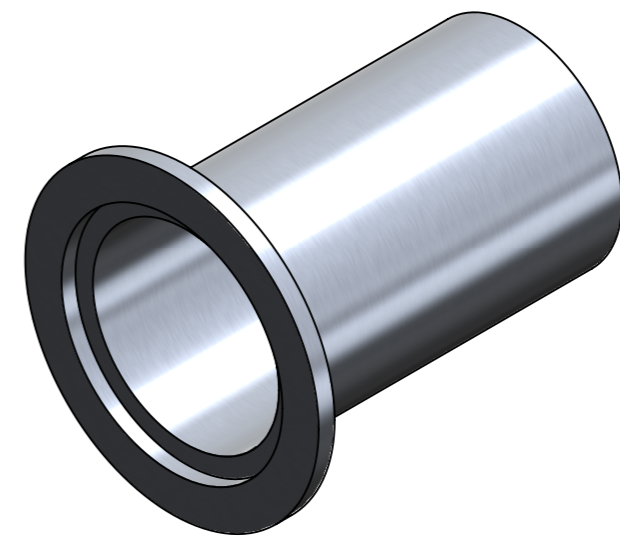
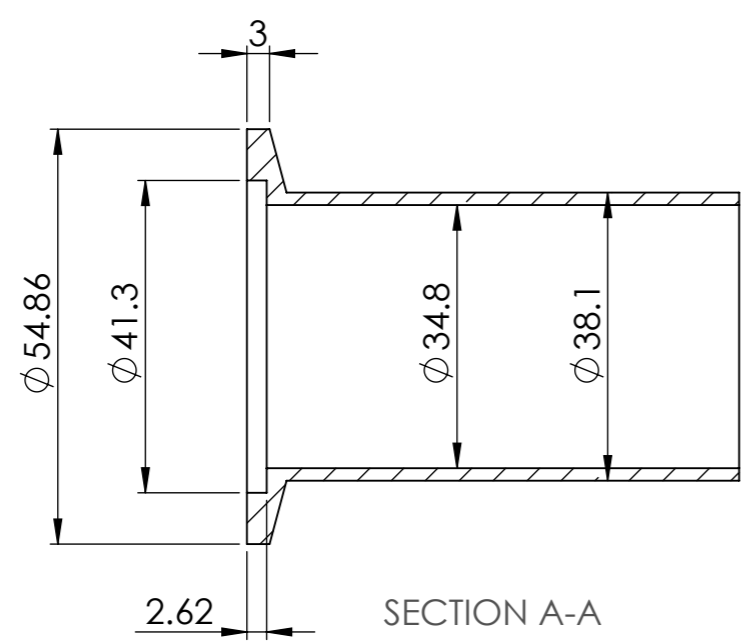
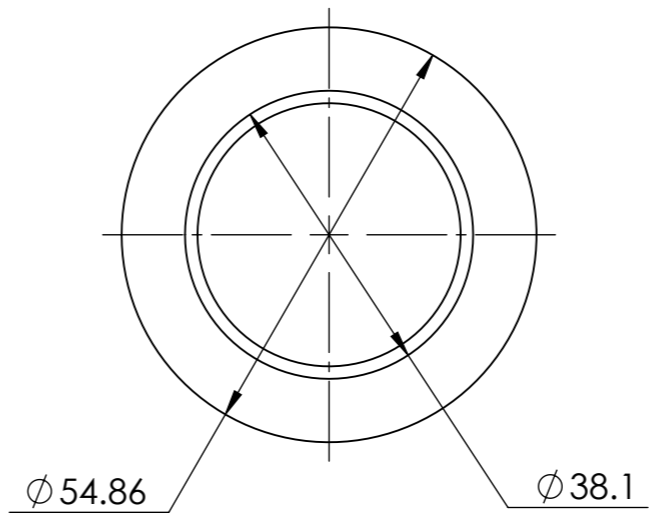
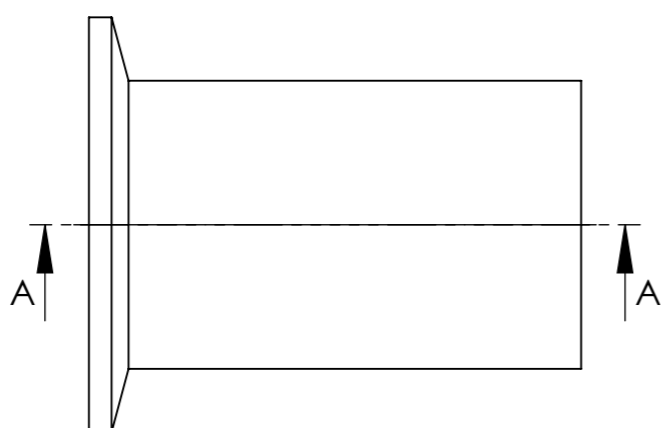

Tolerance for machined surfaces unless otherwise specified		mm	Name	Date	Sign	Sheet	WAVE FREEZEDRYER	
0 DECIMAL PLACES : +/- 0.50mm	0 DECIMAL PLACES : +/- 1.00*	Draw	Thach Ng.	3/21/2024		1/1		
1 DECIMAL PLACES : +/- 0.25mm	1 DECIMAL PLACES : +/- .50*	Control						
2 DECIMAL PLACES : +/- 0.10mm	SURFACE FINISH 125 Ra. MAX	Scale 1:1	Part Number Converter KF 40		Size:	Material		
3 DECIMAL PLACES : +/- 0.02mm	BREAK ALL EDGES TO .35mm x 45*				A4	Material Spec		
<small> CONCENTRICITY .25mm TIR INSIDE CORNERS 0.4mm - 0.8mm R ALL DIMENSIONS ARE IN MILLIMETERS CHECK HARDNESS AT STAMPED PRODUCT NUMBER LOCATION THIS DRAWING IS THE INTELLECTUAL PROPERTY OF WAVE FREEZEDRYER AND MAY NOT BE REPRODUCED IN WHOLE OR IN PART WITHOUT THE WRITTEN PERMISSION OF THE OWNER. ANY RECIPIENT AGREES BY ACCEPTING AND POSSESSING IT, NOT TO DISCLOSE ANY INFORMATION CONTAINED HEREIN TO ANY PERSON OR ENTITY EXCEPT WITH THE AUTHORITY OF WAVE FREEZEDRYER, OR USE IT FOR ANY OTHER PURPOSE OTHER THAN FOR WHICH IT IS INTENDED. </small>								